

6 Watt

- Energy Efficiency Level VI
- European CoC Tier 2
- Medical and ITE Approvals
- Interchangeable Mains Connectors
- Optional White Versions
- Output Voltages from 5 V to 12 V
- Class II Construction
- 3 Years Warranty



The ACM06 series of wall plug adaptors comply with the latest energy efficiency level VI standards with high active mode efficiency and extremely low no load power consumption. Available with a standard jack plug connector as well as USB versions, these adaptors suit a wide variety of cost sensitive industrial and medical applications while maintaining industry leading performance.

Dimensions:

ACM (body only):

2.89 x 1.21 x 1.67" (73.5 x 30.7 x 42.5 mm)

Models & Ratings

Output Power	Output Voltage	Output Current	Total Regulation ⁽³⁾	Efficiency ⁽⁴⁾	Model Number ^(1,2,5)
6 W	5.0V	1000 mA	5%	80.0%	ACM06US05 ⁽⁶⁾
	9.0V	600 mA	5%	79.8%	ACM06US09
	12.0V	500 mA	5%	82.0%	ACM06US12

Notes

1. Model number is for body only. AC input plugs must be ordered separately, see AC input plug section.
2. Other output voltages available, contact sales for details.
3. Total regulation includes initial set accuracy, line and load regulation.
4. Typical average value measured at 115 VAC.
5. For white case version add suffix '-W' e.g. ACM06US12-W. MOQ applies, contact sales for details.
6. For 5 V version with optional USB type A connector in case, add suffix '-BB', e.g. ACM06US05-BB.

Input

Characteristic	Minimum	Typical	Maximum	Units	Notes & Conditions
Input Voltage	90		264	VAC	
Input Frequency	47		63	Hz	
Input Current			0.2	A	100 VAC
Inrush Current			70	A	240 VAC, cold start at 25 °C
Power Factor					EN61000-3-2, class A
No Load Input Power			75	mW	
Input Protection	Internal fuse in line				

Output

Characteristic	Minimum	Typical	Maximum	Units	Notes & Conditions
Output Voltage	5		12	V	See Models and Ratings table
Minimum Load	0			A	No minimum load required
Start Up Delay			4	s	
Start Up Rise Time		30		ms	
Hold Up Time	10			ms	Full load and 100 VAC
Total Regulation			5	%	See Models and Ratings table
Transient Response			4	% deviation	For a 50% step load change at 0.15 A/μs
Ripple & Noise			150	mV pk-pk	Measured with 20 MHz bandwidth and 10 μF electrolytic in parallel with 0.1 μF ceramic capacitor
Short Circuit Protection					Continuous, trip and restart (hiccup mode) with auto recovery
Temperature Coefficient			0.05	%/°C	

General

Characteristic	Minimum	Typical	Maximum	Units	Notes & Conditions
Efficiency		80		%	Typical average of efficiencies measured at 25%, 50%, 75% and 100% load and 115 VAC input
Energy Efficiency					Level VI
Isolation	4000			VAC	Input to Output, 2 x MOPP
Leakage Current		20	100	µA	At 264 VAC, 60 Hz, from output to ground
Switching Frequency	24		70	kHz	Variable
Mean Time Between Failure	250			kHrs	MIL-HDBK-217F at 25 °C GB
Weight		0.22 (100)		lb (g)	Body only

Environmental

Characteristic	Minimum	Typical	Maximum	Units	Notes & Conditions
Operating Temperature	0		+60	°C	Derate from 100% load at 40 °C to 50% load at 60 °C
Storage Temperature	-20		+85	°C	
Operating Humidity	5		90	%	RH, non-condensing
Operating Altitude			5000	m	
Cooling					Natural convection
Shock					1 m drop onto concrete on each of 6 axes, non operating
Vibration	10		300	Hz	2 g, 0.3 decades/min, 15 mins for each of 3 axes

EMC: Emissions

Phenomenon	Standard	Test Level	Notes & Conditions
Conducted	EN55032	Level B	
Radiated	EN55032	Level B	
Harmonic Current	EN61000-3-2	Class A	
Voltage Flicker	EN61000-3-3		

EMC: Immunity

Phenomenon	Standard	Test Level	Criteria	Notes & Conditions
Medical Device EMC	IEC60601-1-2	Ed.4.0 : 2014	as below	
Low Voltage PSU EMC	EN61204-3	High severity level	as below	
ESD Immunity	EN61000-4-2	±8 kV contact, ±15 kV air	A	
Radiated Immunity	EN61000-4-3	10 V/m	A	
EFT/Burst	EN61000-4-4	Level 3	A	
Surge	EN61000-4-5	Level 2	A	
Conducted Immunity	EN61000-4-6	6 V	A	
Magnetic Fields	EN61000-4-8	30 A/m	A	
Dips and Interruptions	EN61000-4-11	Dip: 100% 10 ms	A	
		Dip: 70% 500 ms	B	
		Int: 100% 5000 ms	B	
	EN60601-1-2	Dip: 30% 25 AC Cycles	A	At 8 angles, A at 115 VAC, B at 100 VAC
		Int: 100% 0.5 AC Cycle		
		Int: 100% 1 AC Cycle	B	
		Int.: >95% 5000 ms	B	

Safety Approvals

Safety Agency	Safety Standard	Notes & Conditions
UL	UL60950-1, UL62368-1	Information Technology
TUV	EN60950-1, EN62368-1	
CB	IEC60950-1, IEC62368-1	
CE	LVD	
CCC	China Compulsory Certification, GB4943	
AU/NZ	AU/NZ 60950.1	
UL	ANSI/AAMI ES 60601-1	Medical, 2 x MOPP
CSA	CSA C22.2 No. 60601	
TUV	EN60601-1	
CB	IEC60601-1	

Mechanical Details

ACM06USXX

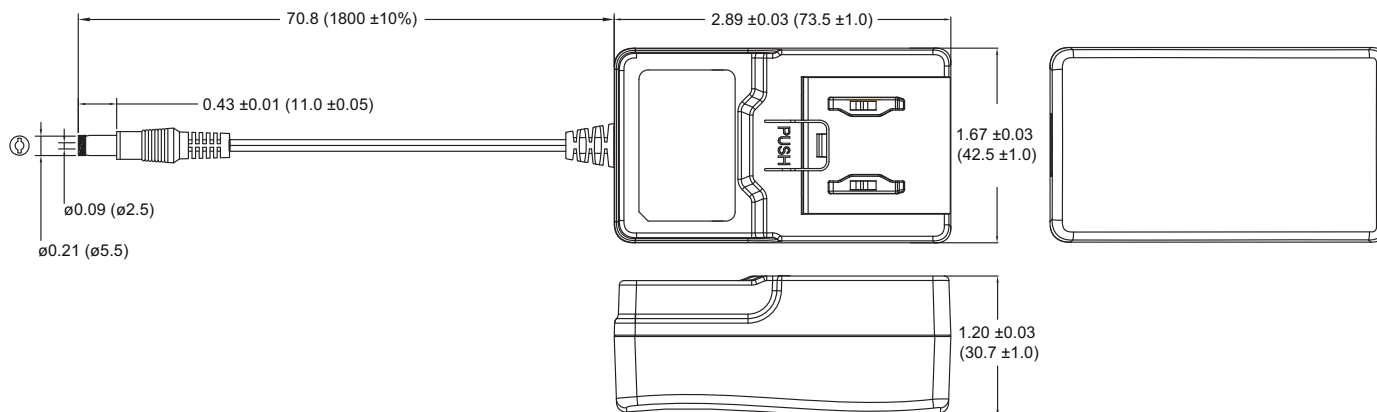

ACM06US05-BB

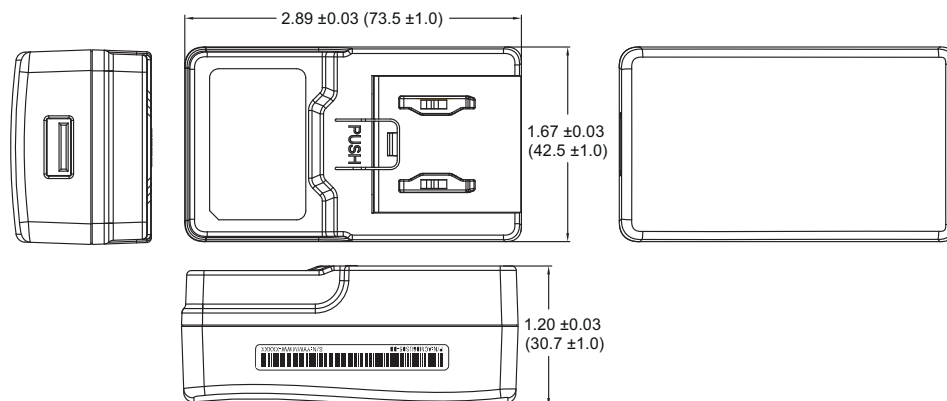

Notes

ACM06USXX output plug $\phi 5.5 \times \phi 2.5 \times 11.0$ mm, centre positive.
 ACM06USXX output lead: UL2468, 18 AWG.

AC Input Plugs

Black UK Plug: ACM PLUG UK
White UK Plug: ACM PLUG UK W

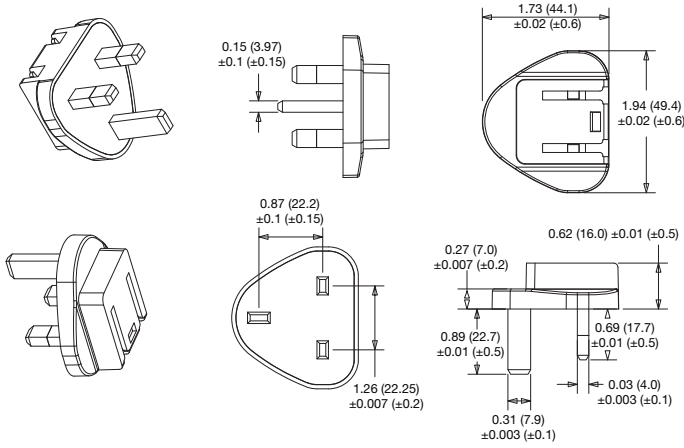

Black USA Plug: ACM PLUG US
White USA Plug: ACM PLUG US W

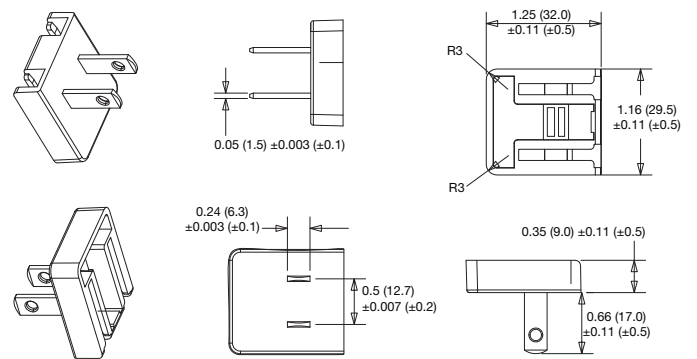

Black Australian Plug: ACM PLUG AU
White Australian Plug: ACM PLUG AU W

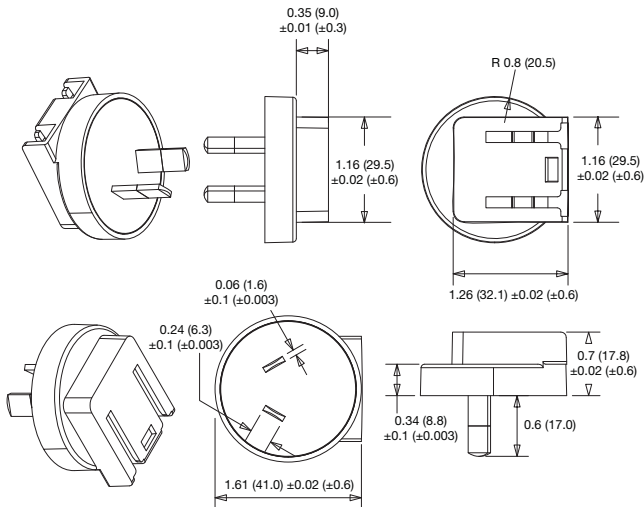

Black European Plug: ACM PLUG EU
White European Plug: ACM PLUG EU W

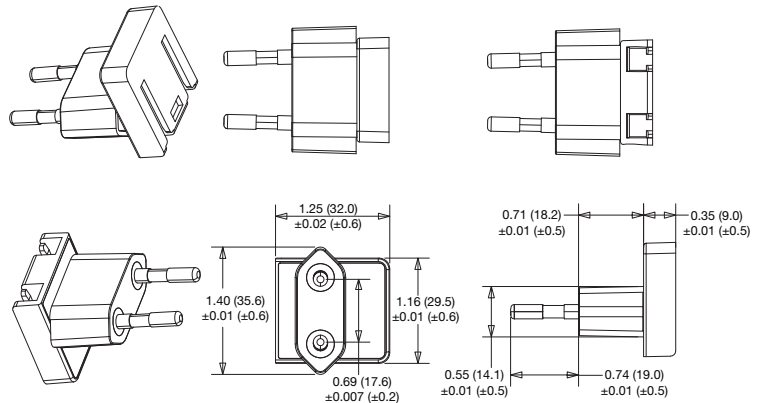

Black China Plug: ACM PLUG CN
White China Plug: ACM PLUG CN W

